

INSTALLATION INSTRUCTIONS FOR MODEL I-B2C (PIECUT) AND MODEL I-B2 (FULL ROUND)

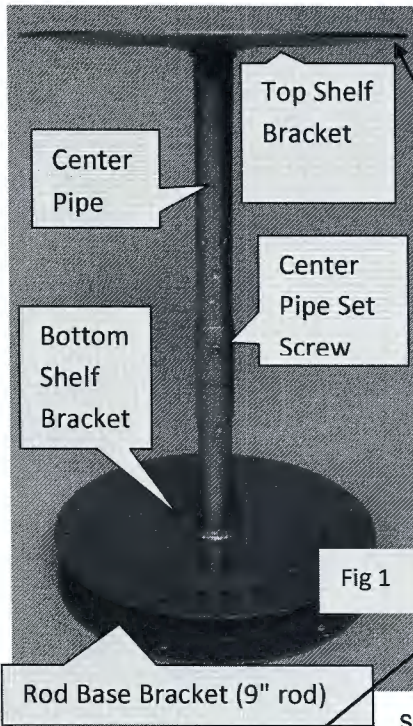

Inside box; locate pack of 18 screws, 2 bearings, 4 washers, and grease syringe. (Model I-B2C already has the bearings and washers installed.)

1 Slide **Top Shelf Bracket** off the top of unit.

2 Loosen **Center Pipe Set Screw** (3/16 Hex Wrench).

3 Slide **Center Pipe** off of **Rod Base Bracket**.

4 Slide **Bottom Shelf Bracket** off of **Rod Base Bracket**.

5 Position **Rod Base Bracket** (9" rod) and screw to floor of cabinet using six #8 X 3/4 Pan hd screws provided. (**Ball Stop** centered with the door on pie-cut, I-B2C Model)

6 (Model I-B2 only) slide one washer, then bearing, and then second washer over **Rod Base Bracket**.

7 Grease Bottom 5" of rod with 1/2 of grease provided in syringe.

8 Cut 1-1/16" hole in center of bottom shelf only, **do not cut hole in top shelf!** (Shelves not Included)

9 Fasten bottom shelf to **Bottom Shelf Bracket** using #8 X 5/8 flat hd screws provided. (Center pie cut where applicable.) Then slide assembled shelf and **Bottom Shelf Bracket** over **Rod Base Bracket**.

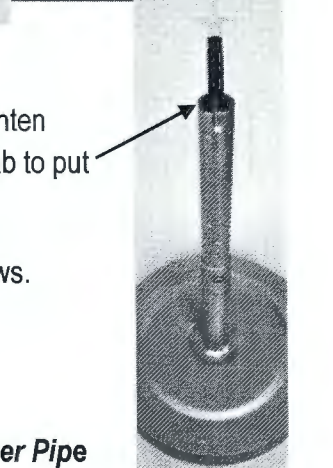
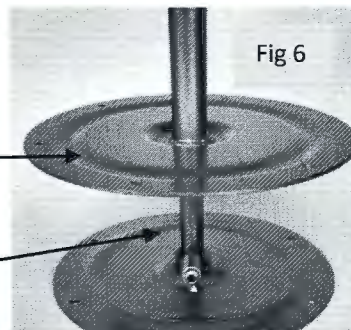
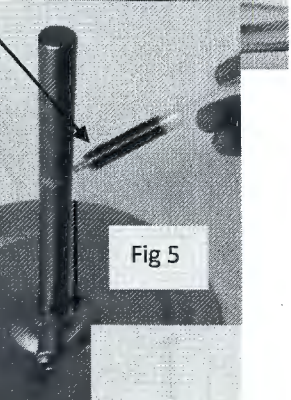
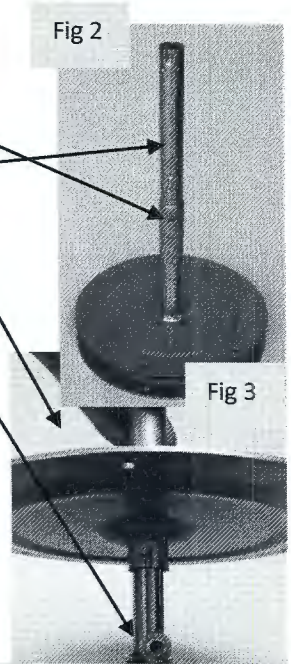
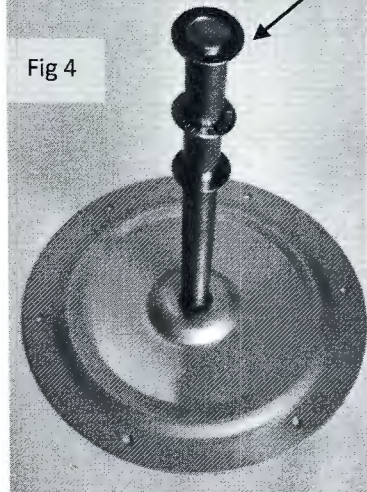

10 Slide **Center Pipe** on top of **Rod Base Bracket** and **Bottom Shelf Bracket** but do not tighten **Center Pipe Set Screw** at this time. Grease inside of the top of **Center Pipe**, saving a tiny dab to put on the **Top Shelf Bracket** bearing.

11 Fasten top shelf to the **Top Shelf Bracket** with six remaining screws. Center pie-cut with catch where applicable.

12 Slide the assembly back into the **Center Pipe**.

13 Make sure both catch balls are in the indentions and the turn **Center Pipe** till both pie-cut shelves are aligned, fasten **Center Pipe Set Screw**.



INSTALLATION PROBLEMS? Call (574) 858 - 9443 or 453-0144

Revolving Shelf Hardware, Manufactured By I D Miller & Sons LLC Bourbon, IN USA