

----- INSTALLATION INSTRUCTIONS -----

FOR MODEL T323 AND MODEL T322 (FULL ROUND) Revolving Shelf Hardware

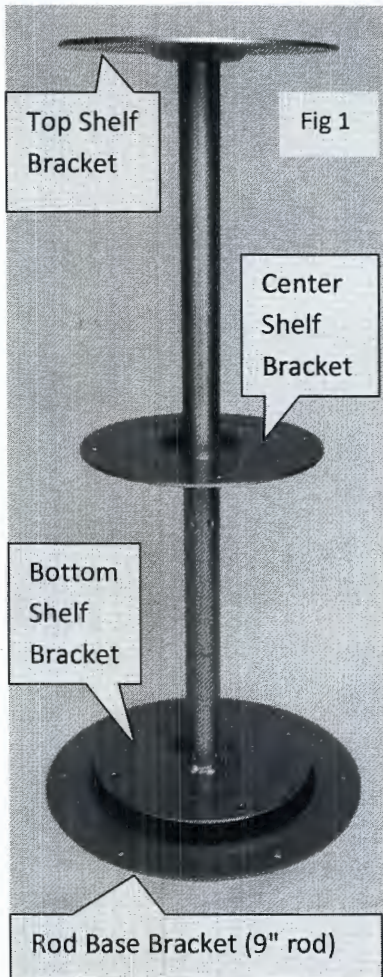

Inside box; locate pack of 18 screws, 1 bearing, 2 washers, and grease syringe. (Note -Model T322 only has 14 screws.)

**1** Cut 1-1/16" hole in center of bottom shelf and middle shelves only, **do not cut hole in top shelf!** (Shelves not Included)

**2** Slide the **Shelf Brackets** assembly off the top of the **Rod Base Bracket**.

**3** Position **Rod Base Bracket** (9" rod) and screw to floor of cabinet using six #8 X 3/4 Pan hd screws provided.

**4** Slide provided washer, then bearing, and then second washer over **Rod Base Bracket** (Fig 2).

**5** Grease full length of **Rod Base Bracket** rod with provided syringe. (See Fig 3)

**6** Unscrew the **Top Shelf Bracket** from the **Center and Bottom Shelf Bracket** (Note - There is no

**Center Shelf Bracket** on Model T322) (See Fig 4)

**7** Fasten shelves to the all **Shelf Brackets** with #8x5/8 flat hd screws provided.

**8** Slide the assembled shelf and **Bottom Shelf Bracket** onto the **Rod Base Bracket**,

**9** Place assembled shelf and **Center Shelf Bracket** over stud.

**9** Follow up with assembled shelf and **Top Shelf Bracket** and carefully thread onto stud (Fig 4).

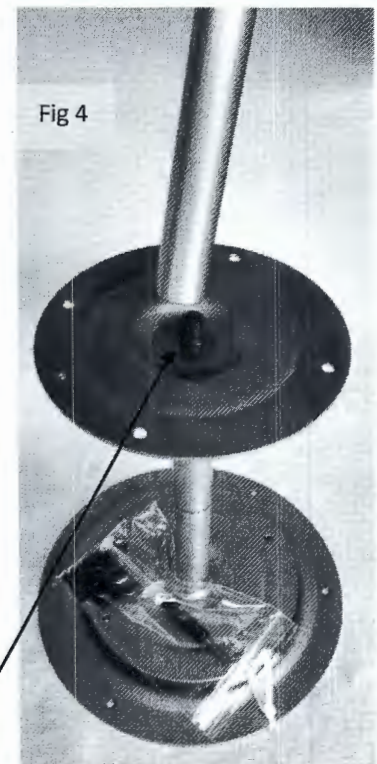
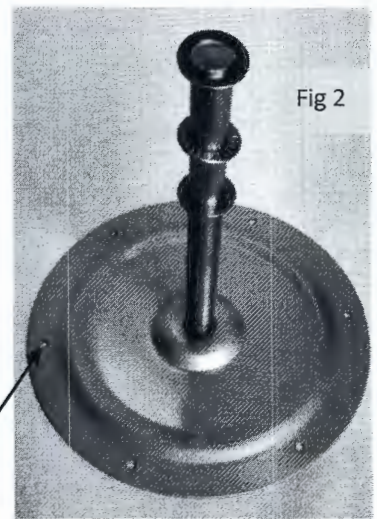

INSTALLATION PROBLEMS? Call (574) 858 - 9443 or 453-0144

Manufactured By I D Miller & Sons LLC Bourbon, IN USA